

Connection to be fully heat welded using rigid 6mm PVC welding rods to form a watertight joint

To provide for uninterrupted through flow, junction shall be flush with either the inside of main line or hole in the main line

100Ø Marley RRJ Connection or similar approved

Roughen surface with uPVC solvent (no grinding permitted) and apply two layers of fibreglass. (chopstrand mat & polyester resin)

Permanent manufacturer's marking to NZS/AS 1260 Standard

150Ø solid wall uPVC SN16 pipe

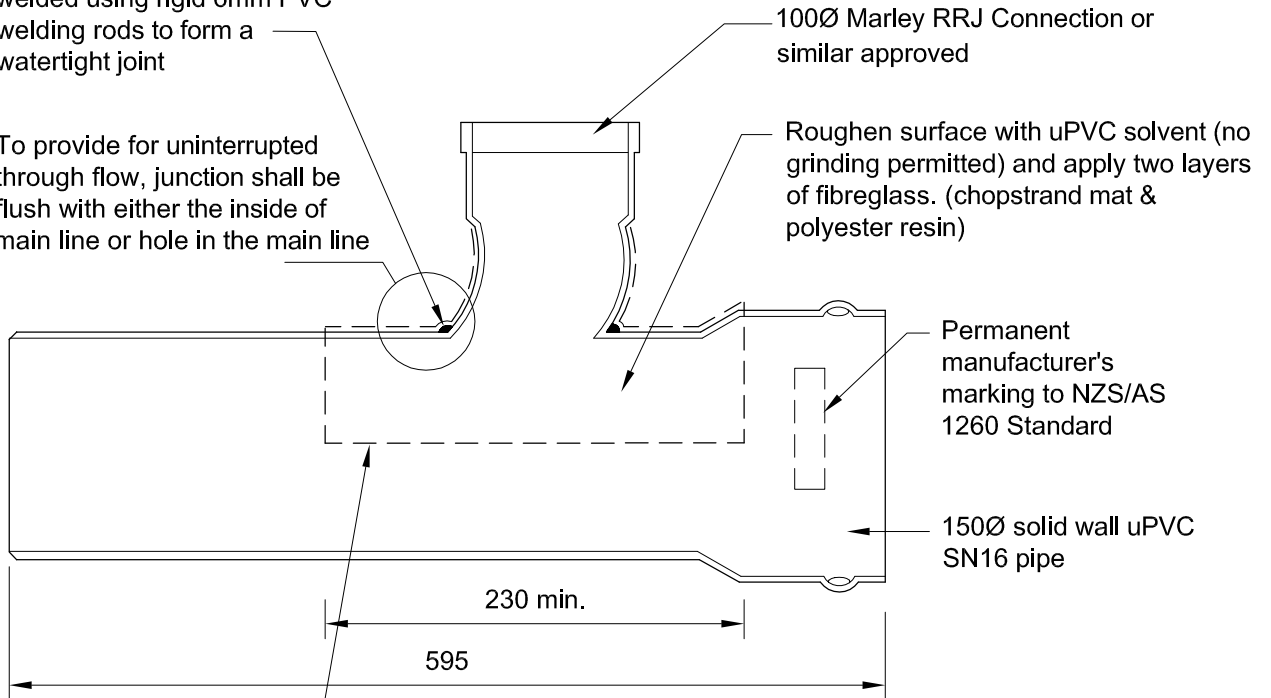

Half pipe diameter fibreglass reinforcing (minimum distance of fibreglass from the rest of the junction to be 50mm)

### Notes:

1. Approval is for the factory assembled unit from solid wall uPVC pipe as manufactured by:
  - a) Plastic Fittings Factory - marked "PFF".
  - b) Strata Screens and Fabrication Ltd - marked "STRATA z.1504.150.100(H.D)L.J".
  - c) Solo Plastics Ltd - marked "z.1504H.150.100L".
2. For use on PVC and mPVC lines only.

**MANARC**

MANUKAU CITY APPROVED  
REQUIREMENT

DETAIL:

PVC LONDON JUNCTION

UPDATED:

AUG 2006

DETAIL No:

MD-24

**MANUKAU CITY COUNCIL**