



# Temporary Signs Bylaw

The purpose of the Temporary Signs Bylaw is to enable people to use a range of temporary signs while ensuring traffic and pedestrian safety, the absence of obstructions and offensive content, and the prevention of damage and misuse of public land, structures and infrastructure in Manukau City.

## What is a Temporary Sign?

A temporary sign means a sign which is portable, mobile or not permanently fixed and to be used for a limited duration of display:

- Advertising the sale or lease of a site or building.
- Advertising cultural, religious, community or sporting events.
- Erected to identify a construction or subdivision site;
- For electioneering purposes.
- For advertising or information.

The Temporary Signs Bylaw applies to signs in public places and to signs on private land visible from a public place.

## Temporary Signs for Advertising or Information (includes sandwich boards)

### Business Zones

- Allowed one sign per ground or first floor premises.
- Sandwich boards must be no more than 1.2m high (including any base) and 0.6m wide (see diagram).
- Banners and flags must not exceed 0.6m<sup>2</sup>.
- If located in a public place:
  - In Business 4, 5 and 6 zones must be placed against the building facade or property boundary, or no closer than 0.4m from the kerb.
  - In any other Business type zone, must be placed against the building facade or property boundary.
  - Must maintain a 2m wide unobstructed footpath.
  - Must not be placed within 2m of a driveway, footpath crossing, pedestrian crossing or bus stop, and not within 5m of an intersection.
  - Must not be placed on any tactile surface for the blind and must have some part of the body of the sign within 0.15m of the ground.
  - Must not be placed on a road or centre medium.
  - Must not otherwise obstruct or endanger pedestrians or vehicles.
  - Must be removed at the end of each business day.

- Four additional signs advertising magazines and newspapers allowed provided the signs are single sided, placed directly against the front wall or display of the business, and be no more than 0.65m high, 0.45m wide and 0.2m deep.
- Must contain the owners name, address and contact phone number, and name and address of the premise to which the sign relates.

### Residential Zones

- Home Enterprises allowed one sign, provided the sign is located on the site and there is no other signage, permanent or temporary.

### Open Space Zones

- No signs are allowed in open space zones (parks).

### Tethered Blimps and Balloons

- May only be located on sites within a Business Zone fronting a primary road (as identified in District Plan).
- Must be flown using at least two guy-ropes.
- Must not be flown higher than 40m above the ground, within 5 km of an aerodrome, outside daylight hours, when wind speeds exceeding 25 km/h or immediately adjacent any motorway or state highway.

### Vehicle Mounted Signs

- Not allowed to use or park a vehicle or trailer on a road for the principal function of advertising.

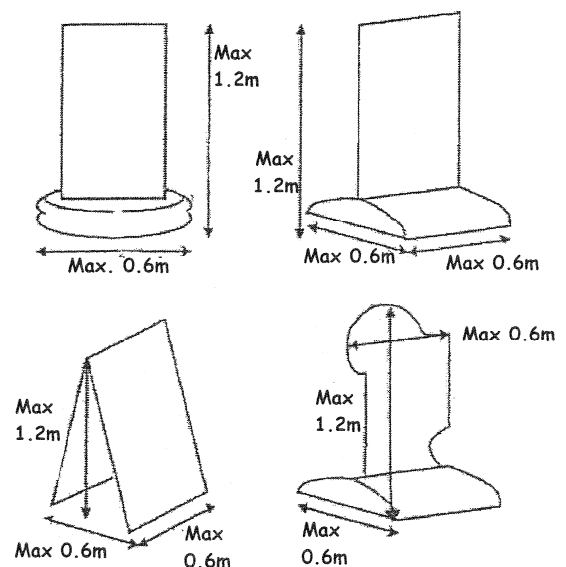

## Temporary Signs for Real Estate

### *For Sale Signs*

- Business type zones allowed one sign per site per agency, each not exceeding 3m<sup>2</sup>.
- Rural type zones allowed two signs per site per agency, each not exceeding 3m<sup>2</sup>.
- Residential, open space and special type zones allowed one sign per site per agency, each not exceeding 2.5m<sup>2</sup>.
- May be located on site or on road zone provided the sign is within 1.2m of the property boundary and does not obstruct carriageway or footpath.
- Must be within profile of host structure.
- May only be displayed for 6 months in any 12 month period.
- Must be removed within 7 days of sale or lease.

### *Open Home or Auction Signs*

- One sign allowed not exceeding 1m<sup>2</sup> during period of open home or auction. Must be located on boundary or within site.
- One flag allowed not exceeding 2m<sup>2</sup> during period of open home or auction. Must be located on boundary, within site, or secured to a legally parked vehicle in a way that does not overhang any road or footpath.

### *Directional Real Estate Signs*

- Allowed 4 free standing directional signs within road zone.
- May only be displayed on the day and immediately prior to the open home or auction and must be removed immediately after the open home or auction.
- Must not have more than 1 direction sign at an intersection.
- Must not exceed 0.25m<sup>2</sup> and 1m in height.
- May only contain agency logo, the words "Open Home" or "Auction", "Next Left" or "Next Right", directional arrow, and time of open home or auction.

## Temporary Signs for a Forthcoming Cultural, Religious, Community or Sporting Event

- Permit required for any sign in Open Space (parks) and Road Zones.
- In all other zones one sign allowed per site frontage per private property per event **provided** it does not exceed an area of 3m<sup>2</sup>, is erected no earlier than one month prior to the event, and is removed within 3 days following that event.

## Temporary Signs for Elections and Polls

- Must be located on private property.
- Must not exceed 3m<sup>2</sup>.
- Must not be fixed to any common boundary fences with a park.
- May be erected no earlier than 2 months prior to election or poll, and must be removed prior to the day of the election or poll.

## Temporary Signs for Construction or Subdivision

- Construction projects allowed one 5m<sup>2</sup> sign.
- Subdivision projects of less than 10 lots allowed one sign per road frontage and one sign within the subdivision, with each sign no more than 3m<sup>2</sup>.
- Subdivision projects of more than 10 lots allowed two signs per road frontage and one sign within the subdivision, with each sign no more than 12m<sup>2</sup>.
- New sites within a subdivision allowed a single sign no more than 0.6m<sup>2</sup> provided the sign is removed within 7 days of sale.
- Show home allowed one 3m<sup>2</sup> sign.
- Must be located on site, must not be in a Road Zone.
- Tethered blimps, balloons, sandwich boards, bunting or banners are not permitted.
- Construction signs must be removed within 7 days of completion.
- Subdivision signs must be removed within 24 months of being erected.

## General Rules for All Temporary Signs

- Must not be illuminated, or use lights, lasers, variable messages or reflective materials.
- Must have permission from the owner/occupier to affix the sign to a building, structure, fence or land.
- Must not be fixed to a park boundary fence and visible to people in the park.
- Must not be attached to public assets, including trees, utility structures, street furniture, light poles, bus shelters, seats, rubbish bins, road signs, public signs, pylons and power poles.
- Must not contain visual or written content that is discriminatory, offensive, threatening, insulting, or likely to encourage unlawful acts or unsociable behaviour.
- Must be maintained in a safe condition, in good order and free of graffiti.
- Must be able to be safely read by motorists.
- Must not obstruct visibility of motorists or pedestrians, cause confusion with road signs or signals, or invite unsafe turning of vehicles.
- Must have a minimum head clearance of 2.4m if hung above a footpath.

### **I Still Have Some Questions, Who Can Help Me?**

In Person:

Customer Centre,

Ground Floor, Kotuku House

4 Osterley Way, Manukau City

Open Monday to Friday 8.30am to 5pm, except Wednesday to 4pm

By Phone: (09) 262 5104

By E-mail: [contactus@manukau.govt.nz](mailto:contactus@manukau.govt.nz)

By Fax: (09) 262 5450

A full copy of Temporary Signs Bylaw can be viewed on the Council website at [www.manukau.govt.nz/bylaws](http://www.manukau.govt.nz/bylaws).

This information sheet summarises the Chapter 19 Temporary Signs of the Manukau City Consolidated Bylaw 2008. This information sheet does not replace any of the requirements of Chapter 19 Temporary Signs.

Information Sheet No: 37; Issue 3: October 2008

